

TECHNICAL DATASHEET



END CAP

03 Update - 04/2024

TECHNICAL DATA

| | |
|------------------------|-------------------|
| Article No | 001 115 0140 0180 |
| d (mm) | 180 |
| le (mm) | 110 |
| s (mm) | 10,7 |
| Weight (Kg) | 1,105 |
| Box Quantity (pcs) | 12 |
| Box Dimension (pcs) | 55x30x37,5 |

INJECTION MOULDED

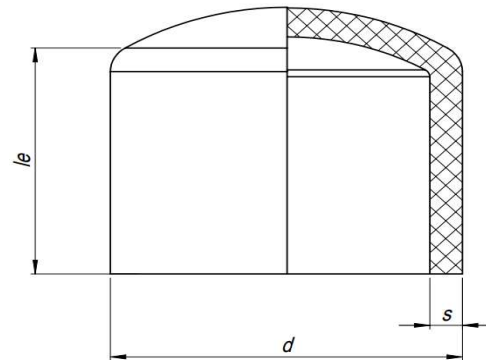

IDENTIFICATION OF PRODUCT

| | |
|----------------|---|
| D(mm) | 180 |
| SDR | 17 |
| RAW METARIAL | PE 100 |
| PRESSURE CLASS | 10 Bar Water 6 Bar Gas |
| TRADEMARK | NTG |
| EXECUTION | Injection Moulded |
| STANDARD | EN 12201-3 EN 1555-3 AS /NZS 4129 |

SPECIFICATION

Long Spigot

Tolerance on diameters and thickness according to the standards. The other dimensions are specialized. Tolerance $\pm 5\%$. NTG PLASTIK reserves all the right to change any information without giving prior notice. The production, distribution and utilization of this document without explicit authorization is prohibited.

Fr 161 Rev 00